



BayoWrap Flame Spec Roof 07

Product Technical
Statement &
Installation Guide



ISSUED: September 2022 | Version 2



Product Technical Statement

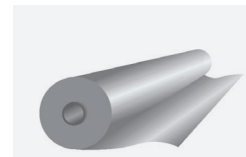

Product

- 1.1 Bayonet BayoWrap Flame Spec Roof 07 is a synthetic building underlay for use under roof claddings. The product consists of a micro-porous water-resistant film laminated to two layers of non woven spun-bonded polyolefin.

Scope

- 2.1 Bayonet BayoWrap Flame Spec Roof 07 is for use as a self supporting roof underlay on buildings within the following:
- The scope limitations of NZBC Acceptable Solution E2/AS1, Paragraph 1.1 with regards to building height and floor plan area; and,
 - with masonry tile roof cladding; and,
 - with metal tile and profiled metal roof cladding; and,
 - situated in NZS 3604 and NASH Standard Part 2 Wind Zones up to and including Extra High.

Building Regulations

New Zealand Building Code (NZBC)

- 3.1 Bayonet BayoWrap Flame Spec Roof 07, if used, designed, installed and maintained in accordance with the statements and conditions within this brochure, will meet, or contribute to meeting the following provisions of the NZBC:

Clause B2 Durability: Performance B2.3.1(a), not less than 50 years, B2.3.1(b), 15 years and B2.3.2. Bayonet BayoWrap Flame Spec Roof 07 meets these requirements. See paragraphs 9.1 & 9.2

Clause C3 Fire Affecting Areas Beyond the Fire Source: Performance C3.4 (c). Bayonet BayoWrap Flame Spec Roof 07 meets this requirement. See paragraph 10.1

Clause E2 External Moisture: Performance E2.3.2. When used as part of the roof cladding system, Bayonet BayoWrap Flame Spec Roof 07 will contribute to meeting this requirement. See paragraphs 12.1 & 12.2

Clause F2 Hazardous Building Materials: Performance F2.3.1. Bayonet BayoWrap Flame Spec Roof 07 meets this requirement.

Technical Specification

- 4.1 Bayonet BayoWrap Flame Spec Roof 07 is a synthetic building underlay for use under roof claddings. The product consists of a micro-porous water-resistant film laminated to two layers of non-woven spun-bonded polyolefin. Bayonet BayoWrap Flame Spec Roof 07 is coloured grey on the top face and white on the bottom face.
- 4.2 Bayonet BayoWrap Flame Spec Roof 07 is supplied in rolls 1.250m wide x 40m long. The product is printed with lap lines of 150mm along each edge for the length of the roll. The rolls are wrapped in clear polythene film.

Accessories

- 4.3 Accessories used with Bayonet BayoWrap Flame Spec Roof 07 which are supplied by the installer are:

Fixings - stainless steel staples, clouts, screws or proprietary underlay fixings, or other temporary fixings to attach the roof underlay to the framing.

Handling & Storage

- 5.1 Handling and storage of the Bayonet BayoWrap Flame Spec Roof 07, whether on or off site, is under the control of the installer. The rolls must be protected from damage and weather. They must be stored on end, under cover, in clean, dry conditions and must not be crushed.

Product Technical Statement

Technical Literature

6.1 Refer to the appraisals listing on the BRANZ website for details of the current Technical Literature for Bayonet BayoWrap Flame Spec Roof 07. The technical literature must be read in conjunction with the appraisal. All aspects of design, use, installation and maintenance contained in the technical literature and within the scope of the appraisal must be followed.

Design Information – General

- 7.1 Bayonet BayoWrap Flame Spec Roof 07 is suitable for use at roof pitches 3° and above. When used at pitches less than 10°, Bayonet BayoWrap Flame Spec Roof 07 can be installed horizontally or vertically when fully supported by a corrosion resistant roof underlay support. At pitches 10° or greater, Bayonet BayoWrap Flame Spec Roof 07 can be installed vertically or horizontally, spanning no greater than 1200mm between supports.
- 7.2 Bayonet BayoWrap Flame Spec Roof 07 is intended for use as an alternative to conventional kraft paper roof underlays, which are fixed over timber or steel framed roofs in order to limit the entry of wind into the roof cavity, and to assist in the moisture management of the roof cladding system.
- 7.3 The material also provides a degree of temporary weather protection during early construction. However, the product will not make the roof weathertight, and some wetting of the underlying structure is always possible before the roof cladding is installed. Hence, the entire building must be closed-in and made weatherproof before moisture sensitive materials such as ceiling linings and insulation materials are installed.
- 7.4 Bayonet BayoWrap Flame Spec Roof 07 must not be exposed to the weather or ultraviolet (UV) light for a total of more than 7 days before being covered by the roof cladding.

75 Bayonet BayoWrap Flame Spec Roof 07 is suitable for use under roof claddings on buildings as a roof underlay as called up in NZBC Acceptable Solution E2/AS1, Table 23. Refer to Table 1 for the material properties of Bayonet BayoWrap Flame Spec Roof 07.

Table 1. NZBC E2/AS1 Table 23 Requirements

| NZBC E2/AS1 Table 23 Roof Underlays Properties | Property Performance Requirement | Results |
|--|----------------------------------|---|
| Absorbency | ≥150 g/m ² | Pass |
| Vapour Resistance | ≤7 MN s/g | Pass |
| Water Resistance | ≥100 mm | Pass |
| pH of Extract | ≥5.5 and ≤ 8.0 | Pass |
| Shrinkage | ≤0.5% | Pass |
| Mechanical | Edge tear and tensile strength | Edge tear (Average): Machine direction = 242 N Cross direction = 139 N Tensile strength (Average): Machine direction = 8 kN/m Cross direction = 5 kN/m |

Product Technical Statement

Structure

8.1 Bayonet BayoWrap Flame Spec Roof 07 is suitable for use in all BuildingWind Zones of NZS 3604 up to, and including, Extra High.

Durability

9.1 Bayonet BayoWrap Flame Spec Roof 07 meets code compliance with NZBC Clause B2.3.1 (a), not less than 50 years for roof underlays used where the roof cladding durability requirement or expected serviceable life is not less than 50 years, e.g. behind masonry roof tile cladding, and code compliance with NZBC Clause B2.3.1 (b), 15 years for roof underlays used where the roof cladding durability requirement is 15 years.

9.2 Serviceable Life: Provided it is not exposed to the weather or ultra-violet light for a total of more than 7 days, and provided the roof cladding is maintained in accordance with the cladding manufacturer's instructions and the roof cladding remains weather resistant, Bayonet BayoWrap Flame Spec Roof 07 is expected to have a serviceable life equal to that of the roof cladding.

Control of Internal Fire and Smoke Spread

10.1 Bayonet BayoWrap Flame Spec Roof 07 has an AS 1530 Part 2 flammability Index of not greater than 5 and therefore meets the requirements of NZBC Acceptable Solutions C/AS2 Paragraph 4.17.8 b), for surface finish requirements for suspended flexible fabric used as an underlay to exterior cladding that is exposed to view in occupied spaces.

Prevention of Fire Occuring

11.1 Separation or protection must be provided to Bayonet BayoWrap Flame Spec Roof 07 from heat sources such as fireplaces, heating appliances, flues and chimneys. Part 7 of NZBC Verification Method C/VMI and Acceptable Solution C/AS1, and Acceptable Solution C/AS2 provide methods for separation and protection of combustible materials from heat sources.

External Moisture

- 12.1 Bayonet BayoWrap Flame Spec Roof 07 must only be used under roof claddings that meet the requirements of the NZBC, such as those covered by NZBC Acceptable Solution E2/AS1, or roof claddings covered by a valid BRANZ Appraisal.
- 12.2 Bayonet BayoWrap Flame Spec Roof 07, when installed in accordance with the technical literature and the BRANZ Appraisal, will assist in the total cladding system's compliance with NZBC Clause E2.

Installation Information

Installation Skill Level Requirements

- 13.1 Installation must always be carried out in accordance with the Bayonet BayoWrap Flame Spec Roof 07 technical literature and the BRANZ appraisal by competent tradespersons with an understanding of roof underlay installation.
- 13.2 Bayonet BayoWrap Flame Spec Roof 07 cannot be laid under translucent sheeting.

Product Technical Statement

Underlay Installation

- 14.1 Bayonet BayoWrap Flame Spec Roof 07 must be fixed at maximum 300mm centres to all framing members with large-head clouts 20mm long, 6-8mm stainless steel staples, self-drilling screws or proprietary underlay fixings. The membrane must be pulled taut over the framing before fixing.
- 14.2 Bayonet BayoWrap Flame Spec Roof 07 may be installed horizontally or vertically at roof pitches 3° and above. It must extend from the ridge and overhang the fascia board by 20mm. Vertical laps must be no less than 150mm wide. Horizontal laps must also be no less than 150mm, with the direction of the lap ensuring that water is shed to the outer face of the Underlays. End laps must be made over framing and be no less than 150mm wide.
- 14.3 When fixing the product in windy conditions, care must be taken due to the large sail area created.
- 14.4 Any damaged areas of Bayonet BayoWrap Flame Spec Roof 07, such as tears, holes or gaps around service penetrations, must be repaired. Damaged areas can be repaired by covering with new material lapping the damaged area by at least 150mm and taping, or by taping small tears.

Inspections

- 14.5 The Technical Literature must be referred to during the inspection of Bayonet BayoWrap Flame Spec Roof 07 installations.

Basis of Appraisal

The following is a summary of the technical investigations carried out: Tests

- 15.1 The following tests have been carried out on Bayonet BayoWrap Flame Spec Roof 07 in accordance with NZBC Acceptable Solution E2/AS1, Table 23: tensile strength, edge-tear resistance and resistance to water vapour transmission in accordance with AS/NZS 4200.1, shrinkage in accordance with AS/NZS 4201.3, resistance to water penetration in accordance with AS/NZS 4201.4, surface water absorbency in accordance with AS/NZS 4201.6 and pH of extract in accordance with AS/NZS 1301.421s. A range of these tests were completed before and after Bayonet BayoWrap Flame Spec Roof 07 was exposed to ultra-violet light.
- 15.2 The flammability index of Bayonet BayoWrap Flame Spec Roof 07 has been evaluated in accordance with AS 1530.2
- 15.3 This product has been both BRANZ appraised (Appraisal No. 715 (2022)) and Codemark certified (CM70104).

Bayonet BayoWrap

Flame Spec

Roof 07

Installation Guide

Installation Guide

Before you start

Installation of Bayonet BayoWrap Flame Spec Roof 07 can be used in warm, cold, and cold non-ventilated normal to pitched roofing systems. In roof construction it is important to recognise that underlays are one of the defence mechanisms in managing internal moisture and should not be used as a compensation for unreliable weatherproofing design or installation. For this reason the requirements of NZBC E2/AS1, New Zealand Metal Roofing Manufacturers Inc. code of practice, NZS 2295:2006, AS4200:Part 2, NASH Building Envelope Solutions: 2019 for Light Steel Framed Buildings and the following list of criteria must be met to comply with the requirements of this technical document:

Safety

Prior to accessing the roof the Best Practice Guidelines for Working on Roofs provided by Ministry of Business, Innovation and Employment (MBIE) must be applied to meet their obligations under the Health and Safety in Employment Act 1992 (HSE Act) and the HSE Regulations 1995.

Care should be taken in handling materials at height. In particular ensure that manual handling regulations are not exceeded. Sufficient edge protection, netting, appropriate scaffolding and lifting equipment are necessary to ensure the safe application of roofing underlays. Before work commences a method statement and risk assessment should be prepared risk mitigation actions implemented.

Timing of installation

The Bayonet BayoWrap Flame Spec Roof 07 can not be left uncladded for which ever is the greater of 7 days or 50 hours of sunshine exposure. Any further sunshine radiation exposure to the product will negatively affect its tensile strength properties.

The commencement of the installation of the roofing underlay can only start once the timber frame moisture content is less than 20% and the relative humidity of the interior of the building is below 75%. A relative humidity of the interior of the building of below 75% will be required before the installation roof underlay for steel frame and concrete buildings. Residual construction moisture will collect on the underlays soon after installation if installed at greater than 75% relative humidity levels.

Where timbers on roofs have been treated with wood preservative due to high moisture content of timbers, it is essential that manufacturer's guidance be sought in relation to chemical attack from preservative on roofing underlay especially treated with solvent based preservatives

The underlay can be used to provide temporary weather protection, as the main function of a roof tile underlay is to provide a secondary barrier to the roof covering, preventing the ingress of wind-driven rain, snow, dust into the roof space and reduce the wind uplift forces acting on the roof covering. However the underlay is not a total waterproof barrier and if it is to be used as a temporary waterproof covering some rain penetration may occur.

In certain conditions, particularly if there is persistent heavy rainfall combined with subsequent severe freeze/thaw conditions, an underlay should not be exposed for more than a one week. To avoid unnecessary damage to the underlay, care must be taken where high winds persist.

Moisture-sensitive internal materials and/or finishes should not be installed until the external roof covering has been completed.

Installation Guide

Installation process

- 1. Safety:** Applied your risk assessment and mitigation actions as per the Best Practice Guidelines for Working on Roofs by (MBIE).
- 2. Pre-Installation conditions:** The roofing system meets the conditions as set out in the “Timing of installation” section on the previous page.
- 3. Product Handling:** Reasonable precautions must be taken in handling the rolls to prevent damage, such as tears or perforations, occurring before and during installation, and prior to the application of the roof covering. The rolls must not be exposed to a naked flame or other ignition source. Damage to the roof underlay greater than 75mm in form of rips or tears requires the underlay to be replaced. Rips up to 75mm can be repaired using Bayonet BayoWrap Window Sealing Tape.
- 4. Unrolling:** Unroll the underlay exactly as per the sketch, such that the inner surface of the roll [coloured side] is facing up.
Roof types:- Laying of underlay can either be horizontal or vertical but the NZBCE2/AS1 prescribes the following according to roof pitch.

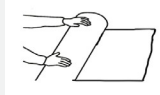

| Roof pitches below 10° | Roof pitches of 10° or above |
|---|------------------------------|
| Run horizontally or vertically | Self supporting |
| When fully supported by a corrosion resistant roof support | |
| Good ventilation design and effective weathertight details need to be applied in conjunction with underlay details for effective moistures control especially with low pitch roofs. | |

- 5. Lapping:** All sides of the underlay must overlap by 150mm. Overlapping of underlay must be kept to a minimum and there are specific requirements for the ends of the underlay that terminate at the ridge, eaves, abutments and roof protrusions (see items 7-23).
- 6. Supports:** Bayonet BayoWrap Flame Spec Roof 07 is strong enough to support its own weight up to a 1200 mm span.

- 7. Ridges:** All underlay is terminated at the ridge, and if not it should be slit or slotted to allow passive ventilation of the ceiling cavity.

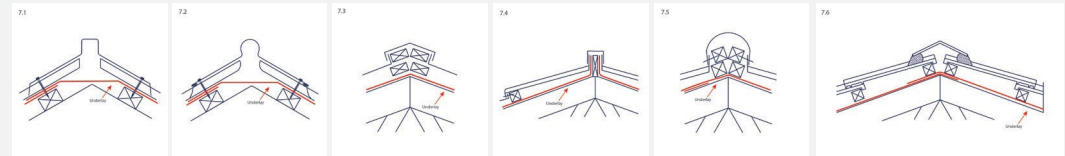

- 8. Eaves:** The underlay should terminate on the upper side of the eaves flashing or overhang fascia by no more than 20 mm to prevent wicking.

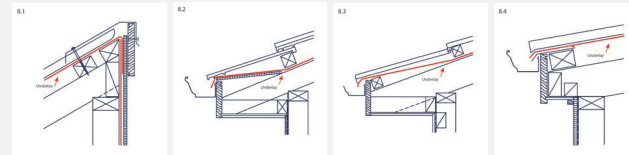

- 9. Barge:** The underlay should terminate to the highest point, either the top of the barge board or meet the metal barge flashing except for horizontal profiled metal where the underly is used to separate the metal from timber.

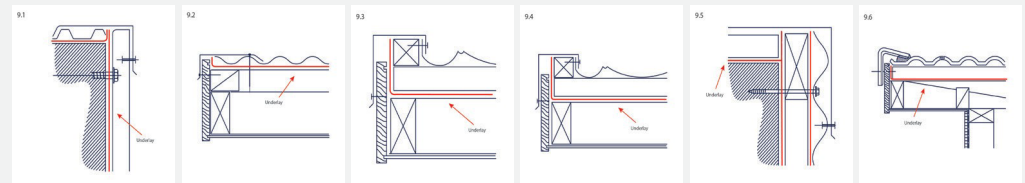

SYNTHETIC

Installation Guide

10. Aprons: The underlay lap should terminate at a minimum of 150mm from the roof edge to the wall and separate any metal aprons flashing from the wall/ timber.

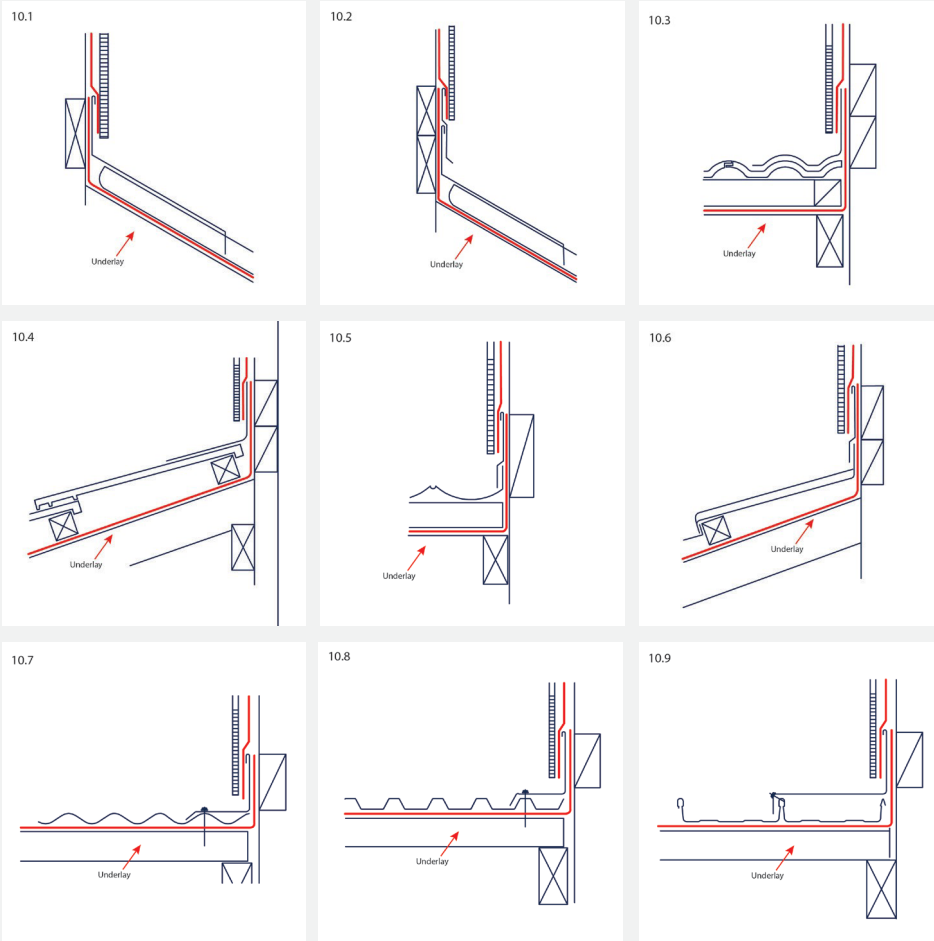

11. Aprons flashing and change in roof pitch: The underlay lap should terminate at the end of the apron flashing so as to any metal apron flashing from the supporting roof structure.

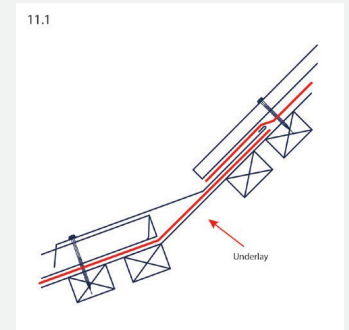

12. Abutment: The underlay is to cover the gutter lining under the roof area and overlap into the gutter by a maximum of 20 mm to prevent wicking.

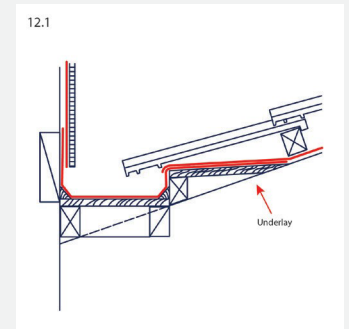

13. Parapet and enclosed balustrades: The underlay is to provide separation of the metal and timber.

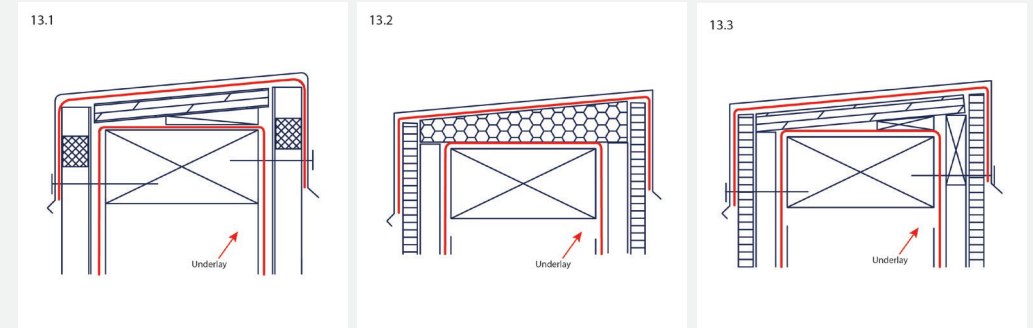

Installation Guide

- 14. Penetrations:** All roof penetrations that pass through the roof underlay will be installed by star-cutting the underlay carefully to prevent tears, closely fitted over the pipe, ensuring that all the tabs project upwards along the pipe, and then the tabs taped around the circumference of the pipe using a flexible flashing tape compiling with Parts 3.2 and 4 of ICBO Acceptance Criteria AC148, shall be compatible or roof underlay, and be used only in fully concealed applications.
- 15. Vented Cavity Battens:** The underlay should be positioned on the upper side of the batten, directly under the roof covering allowing the battens to vent the roof cavity directly.

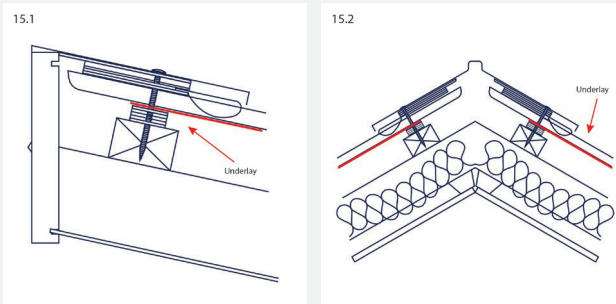

- 16. Thermal breaks:** The underlay is to be installed between the roof covering and the insulating spacer to avoid thermal bridging.

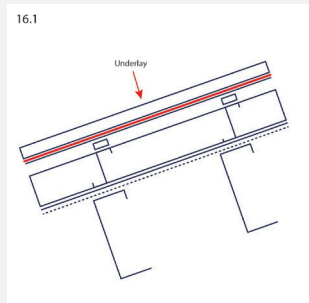

- 17. Cold roofs and insulation:** In cold roof construction, the insulation is at ceiling level and there is an air gap between the insulation and the roof underlay of at least 25mm.

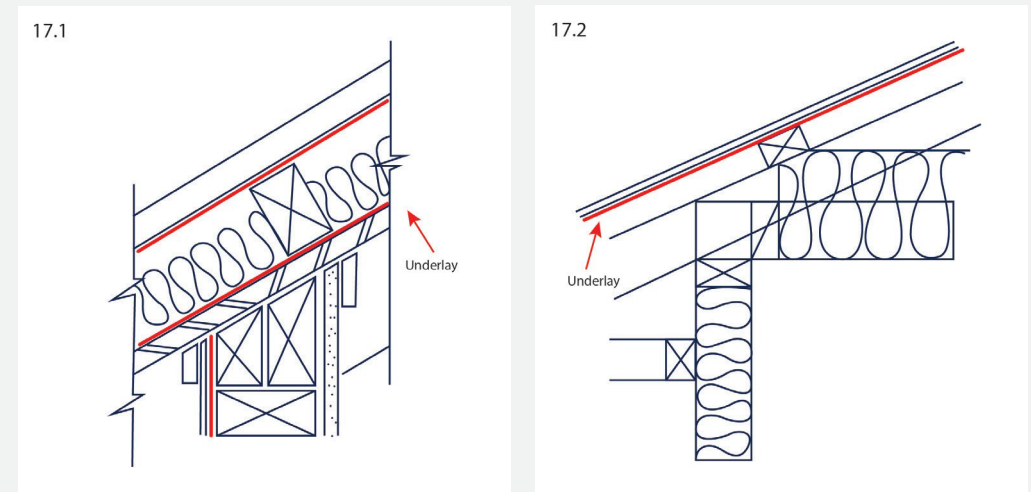

- 18. Separation from sources of heat:** Underlays being combustible materials must be separated from chimneys, flues, fire places and heating appliances as indicated in Part 7 of NZBC Acceptable Solutions C/AS1-C/AS6 and NZBC Verification Method C/VM1.
- 19. Accidental ignition:** Underlays have the risk of fire spread when used unsupported, should the material be accidentally ignited during maintenance works, etc. (e.g. by a roofer or plumbers torch). As with all types of sarking and bituminous material, care must be taken during building and maintenance to avoid the material becoming ignited.

Installation Guide

- 20. Fixings of roof underlay:** If the underlay is laid during roof or batten installation then the fixings used will be normally permanent through the roof, battens or purlins and comply with the specific design requirements of the building including the NZBC. If the temporary fixing is required then it must be fixed at maximum centres to all framing members with large head clouts 20mm long, 6-8mm stainless steel staples, self drilling screws or proprietary underlay fixings and the underlay must be pulled taut over the framing before fixing.
- 21. Ultraviolet Radiation:** Once the underlay is installed and covered with the roof covering, it must not be exposed to the weather or direct ultra-violet light for long periods. It is recommended that any transparent cladding or windows have UV filters in place to prevent the degradation of the underlay over time as the UV reflective properties of white paint, concrete and asphalt range from 4-22% and will reduce the serviceable life of the underlay to that of the roof cladding.
- 22. Loading Underlay:** Bayonet BayoWrap Flame Spec Roof 07 is not designed to withstand the weight of an installer, tiles, roofing material being loaded out. Purlins must therefore be installed as work progresses from eaves to ridge for achieving support for feet and avoiding damage to the underlay surface. No materials or implements should be resting on the underlay. Where pressure on the underlay over a rafter is unavoidable, it should be noted that the underlay does not offer substantial grip, particularly at overlaps or when wet.
- 23. Repairing Installed Underlay:** Where the underlay becomes damaged for whatever reason, repairs can be carried out by overlaying the damaged area with a layer of additional material ensuring a 150mm overlap all round, ensuring that the up-slope side is overlapped by the next highest horizontal run of underlay, and secured under a batten. If the underlay is vertically installed, a full new sheet width will be installed from and fixed to the purlin below the damaged area to two purlins above the damaged area, fitted to under the old sheet and fixed to the purlin.